

BETREFF

**Technische Daten
Einstellmaße und Toleranzen
Isabella und Isabella-Combi**

ORDNER
PKW 1
ABLAGÉ-GRUPPE
00
RUNDSCHREIBEN
1
NUMMER

(Angaben vorbehaltlich, da diese ggf., durch technische Neuerungen bedingt, Veränderungen unterliegen.)

(Ausgabe vom 3.4.60)

Gruppe 00 Allgemeine technische Angaben

	<u>Isabella</u>	<u>Isabella-Combi</u>	
Baureihe des Fahrgestells Baureihe des Motors Bauart des Motors Fahrgestellnummer (ab 1954 ab 1956 ab 1959) Motornummer 4 M 1,5 II (ab 1954 ab 1956)	4 M 1,5 II 4 Takt - Otto 540 001 - 750 000 1 100 001 - 1 137 800 1 140 001 -	230 001 - 249 375 310 001 - 560 001 - 610 000 1 000 001 -	
<u>Abmessungen</u> a) Radstand b) Spurweite vorn hinten Wendekreis-Ø ca. c) Bodenfreiheit bel. ca. d) Fahrzeug - Länge e) Breite f) Höhe g) Ladefläche Länge bis Vordersitz h) bis Hintersitz Breite i) Höhe k) Höhe über Fahrbahn unbel. l) Rückwandtür-Breite oben u. unten m) Höhe	260 mm 1346 mm 1370 mm 11 m 175 mm 4400 mm 1760 mm 1500 mm	188 mm 880 mm 938 mm/1090 mm 778 mm	
<u>Gewichte</u> zul. Gesamtgewicht Leergewicht a) zul. Belastung/Nutzlast b) zul. Vorderachsdruk c) zul. Hinterachsdruk zul. Anhänger-Gesamtgewicht gebremst ungebremst d) max. Dachbelastung Motorgewicht (ohne Wasser u. Öl)	1415 kg 1050 kg 5 Pers. + 40 kg 780 kg 560 kg	1650 kg 1205 kg (mit Fahrer) 440 kg 1000 kg 800 kg 600 kg 100 kg 130 kg	bei 640-1000 mm Dachhöhe
<u>Füllmengen</u> a) Motor-Ölwechsel b) Kühlanlage Frostschutzmittel bis -20° C bis -30° C Kraftstoffbehälter c) Getriebe-Ölwechsel d) Hinterachs-Ölwechsel Ölbadluftfilter (Spezialausf.)	4 l 7 l 2,5 l 3 l 46 l 1 l 1,5 l (Neufüllung 2 l) 0,2 l		

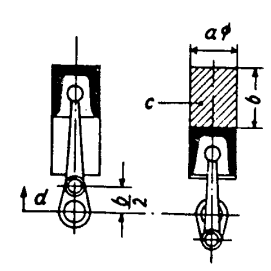
	<p><u>Leistungen</u></p> <p>Zylinderzahl 4</p> <p>Zylinderanordnung in Reihe</p> <p>a) Zylinderbohrung 75 \varnothing mm</p> <p>b) Hub 84,5 mm</p> <p>c) Hubraum 1493 cm³</p> <p>Verdichtungsverhältnis 1 : 7</p> <p>Höchstleistung bei 4700 U/min 60 PS (nach DIN 70020)</p> <p>d) max. Drehmoment bei 2500 U/min 11 mkg</p> <p>Literleistung 40 PS/l</p> <p>Niedr. Kraftstoffverbrauch 223 g/Psh bei 2700 U/min</p> <p>Mittlere Kolbengeschwindigkeit bei Höchstleistung 13,2 m/sek</p> <p>Spez. Drehzahl des Motors bei 60 km/h (Isabella) 2140 U/min (Combi) 2040 U/min</p> <p>Mittl. Arbeitsdruck bei max. Drehm. Höchstleistung 9,2 kg/cm² 7,7 kg/cm²</p> <p>Kraftstoffverbrauch nach DIN 70030 (bei Meßgeschwindigkeit 98 km/h) 9,1 l/100 km</p>	
---	---	--

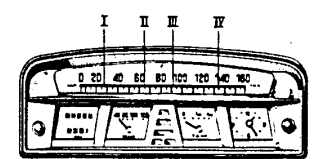
	<p><u>Höchstgeschwindigkeit in den Gängen</u></p> <p>1. Gang (I) 33 km/h</p> <p>2. Gang (II) 62 km/h</p> <p>3. Gang (III) 96 km/h</p> <p>4. Gang (IV) 130 km/h</p> <p>Rückwärts-Gang ca. 20 km/h</p>	<p>bei 4700 U/min</p>
---	--	-----------------------

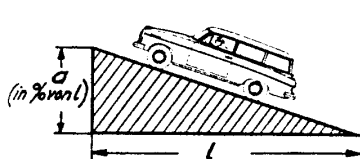
	<p>a) <u>Steigfähigkeit in den Gängen</u></p> <p>1. Gang 40 %</p> <p>2. Gang 21 %</p> <p>3. Gang 13 %</p> <p>4. Gang 9 %</p> <p>Rückwärts-Gang 42 %</p>	<table border="1"> <thead> <tr> <th></th> <th>Isabella</th> <th>Isabella Combi</th> </tr> </thead> <tbody> <tr> <td>1. Gang</td> <td>40 %</td> <td>36 %</td> </tr> <tr> <td>2. Gang</td> <td>21 %</td> <td>18 %</td> </tr> <tr> <td>3. Gang</td> <td>13 %</td> <td>11 %</td> </tr> <tr> <td>4. Gang</td> <td>9 %</td> <td>7 %</td> </tr> <tr> <td>Rückwärts-Gang</td> <td>42 %</td> <td>38 %</td> </tr> </tbody> </table>		Isabella	Isabella Combi	1. Gang	40 %	36 %	2. Gang	21 %	18 %	3. Gang	13 %	11 %	4. Gang	9 %	7 %	Rückwärts-Gang	42 %	38 %
	Isabella	Isabella Combi																		
1. Gang	40 %	36 %																		
2. Gang	21 %	18 %																		
3. Gang	13 %	11 %																		
4. Gang	9 %	7 %																		
Rückwärts-Gang	42 %	38 %																		

Gruppe O3 Federung und Stoßdämpfer

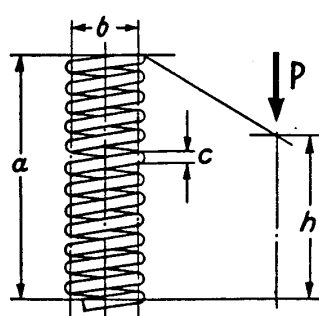
	<p><u>Vorderfeder-Bauart</u></p> <p>a) Länge unbelastet</p> <p>b) Feder \varnothing</p> <p>c) Federdraht \varnothing</p> <p>Anzahl der wirks. Windungen</p> <p>Federrate (pro cm Federweg)</p> <p>Federgruppe durch Farbstrich gekennzeichnet: rot Bei Einbau sind nur Federn gleicher Farb- zeichen zu verwenden gelb grün</p> <p>max. Federbelastung bei Länge</p>	<p>Schraubenfeder</p> <p>345 mm</p> <p>91 \varnothing mm</p> <p>14,6 \varnothing mm</p> <p>11,5</p> <p>54 kg/cm \pm 4 %</p> <p>P bei h) = 260 mm</p> <p>432,2 - 448,4 kg</p> <p>448,5 - 463,6 kg</p> <p>463,7 - 478,8 kg</p> <p>769 kg/202 mm</p>
---	--	--

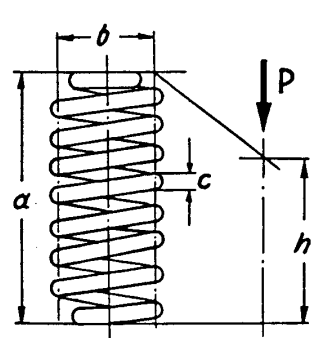
	<p><u>Hinterfeder - Bauart</u></p> <p>a) Länge unbelastet</p> <p>b) Feder \varnothing</p> <p>c) Federdraht \varnothing</p> <p>Anzahl der wirks. Windungen</p> <p>Federrate (pro cm Federweg)</p> <p>Federgruppe durch Farbstrich gekennzeichnet: rot Bei Einbau sind nur Federn gleicher Farb- zeichen zu verwenden gelb grün</p> <p>max. Federbelastung bei Länge</p>	<table border="1"> <thead> <tr> <th></th> <th>Isabella</th> <th>Isabella Combi</th> </tr> </thead> <tbody> <tr> <td>Schraubenfeder</td> <td>~ 366 mm</td> <td>~ 341 mm</td> </tr> <tr> <td></td> <td>130 \varnothing mm</td> <td>130 \varnothing mm</td> </tr> <tr> <td></td> <td>13,8 \varnothing mm</td> <td>13,6 \varnothing mm</td> </tr> <tr> <td></td> <td>7,5</td> <td>8,5</td> </tr> <tr> <td></td> <td>22 kg/cm</td> <td>38 kg/cm</td> </tr> <tr> <td>P bei h) = 230 mm</td> <td></td> <td>P bei h) = 210 mm</td> </tr> <tr> <td></td> <td>285 - 295 kg</td> <td>475 - 491,5 kg</td> </tr> <tr> <td></td> <td>295,1 - 305 kg</td> <td>491,6 - 508,5 kg</td> </tr> <tr> <td></td> <td>305,1 - 315 kg</td> <td>508,6 - 525 kg</td> </tr> <tr> <td></td> <td>490 kg/146 mm</td> <td>690 kg/160 mm</td> </tr> </tbody> </table>		Isabella	Isabella Combi	Schraubenfeder	~ 366 mm	~ 341 mm		130 \varnothing mm	130 \varnothing mm		13,8 \varnothing mm	13,6 \varnothing mm		7,5	8,5		22 kg/cm	38 kg/cm	P bei h) = 230 mm		P bei h) = 210 mm		285 - 295 kg	475 - 491,5 kg		295,1 - 305 kg	491,6 - 508,5 kg		305,1 - 315 kg	508,6 - 525 kg		490 kg/146 mm	690 kg/160 mm
	Isabella	Isabella Combi																																	
Schraubenfeder	~ 366 mm	~ 341 mm																																	
	130 \varnothing mm	130 \varnothing mm																																	
	13,8 \varnothing mm	13,6 \varnothing mm																																	
	7,5	8,5																																	
	22 kg/cm	38 kg/cm																																	
P bei h) = 230 mm		P bei h) = 210 mm																																	
	285 - 295 kg	475 - 491,5 kg																																	
	295,1 - 305 kg	491,6 - 508,5 kg																																	
	305,1 - 315 kg	508,6 - 525 kg																																	
	490 kg/146 mm	690 kg/160 mm																																	

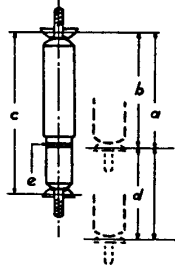
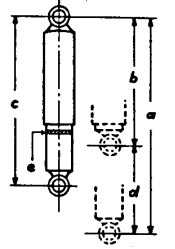
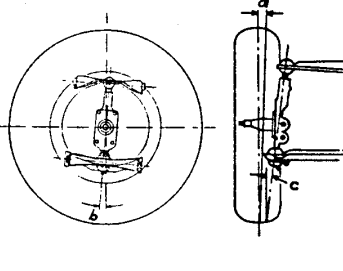
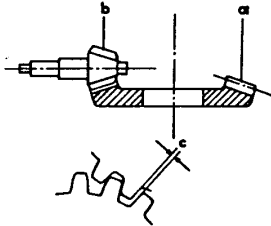
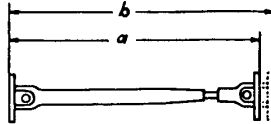
<p><u>Stoßdämpfer vorn 055 033 01 05/09</u></p> <p>a) Länge - ausgezogen b) - zusammengedrückt c) - Einbau d) Hub Prüfhub Drehzahl Zugstufe Druckstufe e) Toleranz Kennzeichen</p>	<table border="1"> <thead> <tr> <th>05 (Fa. Boge)</th> <th>09 (Fa. Stabilus)</th> </tr> </thead> <tbody> <tr> <td>299 mm</td> <td></td> </tr> <tr> <td>199 mm</td> <td></td> </tr> <tr> <td>250 mm</td> <td></td> </tr> <tr> <td>100 mm</td> <td></td> </tr> <tr> <td>25 mm 75 mm</td> <td>25 mm 75 mm</td> </tr> <tr> <td>100 U/min</td> <td>100 U/min</td> </tr> <tr> <td>60±15 kg* 215±20 kg*</td> <td>70±10 kg* 190±15 kg*</td> </tr> <tr> <td>20±10 kg* 60±10 kg*</td> <td>40± 8 kg* 50± 8 kg*</td> </tr> </tbody> </table> <p>* (Plus ohne / Minus mit Tesakreppband)</p>	05 (Fa. Boge)	09 (Fa. Stabilus)	299 mm		199 mm		250 mm		100 mm		25 mm 75 mm	25 mm 75 mm	100 U/min	100 U/min	60±15 kg* 215±20 kg*	70±10 kg* 190±15 kg*	20±10 kg* 60±10 kg*	40± 8 kg* 50± 8 kg*	
05 (Fa. Boge)	09 (Fa. Stabilus)																			
299 mm																				
199 mm																				
250 mm																				
100 mm																				
25 mm 75 mm	25 mm 75 mm																			
100 U/min	100 U/min																			
60±15 kg* 215±20 kg*	70±10 kg* 190±15 kg*																			
20±10 kg* 60±10 kg*	40± 8 kg* 50± 8 kg*																			
<p><u>Stoßdämpfer hinten 055 033 01 06/10</u></p> <p>a) Länge - ausgezogen b) - zusammengedrückt c) - Einbau d) Hub Prüfhub Drehzahl Zugstufe Druckstufe e) Toleranz Kennzeichen</p>	<table border="1"> <thead> <tr> <th>06 (Fa. Boge)</th> <th>10 (Fa. Stabilus)</th> </tr> </thead> <tbody> <tr> <td>306 mm</td> <td></td> </tr> <tr> <td>223 mm</td> <td></td> </tr> <tr> <td>265 mm</td> <td></td> </tr> <tr> <td>83 mm</td> <td></td> </tr> <tr> <td>25 mm</td> <td>75 mm</td> </tr> <tr> <td>190 U/min</td> <td>100 U/min</td> </tr> <tr> <td>100 ± 15 kg*</td> <td>215 ± 20 kg*</td> </tr> <tr> <td>45 ± 10 kg*</td> <td>65 ± 10 kg*</td> </tr> </tbody> </table> <p>* (Plus ohne / Minus mit Tesakreppband)</p>	06 (Fa. Boge)	10 (Fa. Stabilus)	306 mm		223 mm		265 mm		83 mm		25 mm	75 mm	190 U/min	100 U/min	100 ± 15 kg*	215 ± 20 kg*	45 ± 10 kg*	65 ± 10 kg*	
06 (Fa. Boge)	10 (Fa. Stabilus)																			
306 mm																				
223 mm																				
265 mm																				
83 mm																				
25 mm	75 mm																			
190 U/min	100 U/min																			
100 ± 15 kg*	215 ± 20 kg*																			
45 ± 10 kg*	65 ± 10 kg*																			
Gruppe 04 Vorderachse																				
<p><u>Vorderachse - Bauart</u></p> <p>a) Radsturz Vorspur (Räder gedrückt) b) Nachlauf c) Spreizung Spurdifferenzwinkel bei 20° Einschlag</p>	<p>Doppelquerlenker Radwinkel bei 160 kg Belastung der Vordersitze gemessen!</p> <p>0° ± 1° 0 mm 3° ± 30' 6° ± 15' 2°40' ± 30'</p>																			
Gruppe 06 Hinterachse																				
<p><u>Hinterachse - Bauart</u> Hinterachsuntersetzung</p> <p>a) Tellerrad Zähnezahl b) Kegelrad Zähnezahl c) Zahnradflankenspiel zwischen Teller- u. Kegelrad</p>	<p>Doppelgelenk - Pendelachse 1 : 3,9 39 10 0,15 - 0,18 mm</p>																			
Gruppe 07 Gelenkwelle																				
<p><u>Gelenkwelle</u></p> <p>a) zusammengeschobene Länge b) Einbaulänge max. Unwucht</p>	<p><i>p 100</i></p> <p>1278 mm 1300 mm 25 cmgr. (bei 3500 U/min)</p>																			

Gruppe 08 Bremse

	Fabrikat u. Type der Bremse Art	Borgward / Teves Öldruck-Innenbacken-Bremse
	wirksame Gesamtbremsfläche a) Bremsbelag Breite b) Sektor c) Dicke Bremsstrommel \varnothing Ausdreh-Grenzmaß \varnothing d) Hauptbremszylinder e) Hub Radbremszylinder vorn hinten	vorn Duplex hinten Simplex 744 cm ² 8 65 50 mm 100° 110° 6 mm 230 \varnothing mm + 2 mm (232 \varnothing mm) 25,4 \varnothing mm 36 mm <u>Isabella</u> <u>Isabella-Combi</u> 2 x 28,57 \varnothing mm 2 x 25,4 \varnothing mm 22,2 \varnothing mm 25,4 \varnothing mm

Gruppe 11 Lenkung

	Fabrikat Type Übersetzung Lenkradumdrehungen bei Gesamtausschlag a) äußerer Radeinschlag b) innerer Radeinschlag Lenkrad \varnothing	ZF-Gemmer (Rollzahnsegment) GB 16 c 1 : 15,5 3,7 32° 42° 425 \varnothing	Ate - Ross (Einfinger) 511 1 : 14,5 3,22 32° 42° 425 \varnothing
--	--	---	---

Gruppe 12 Räder und Bereifung



	Räder Art Anzahl a) Felgenreöße vorn u. hinten b) Lochkreis \varnothing Anzahl der Löcher c) Reifengröße Luftdruck vorn hinten d) wirksamer Reifenradius (dyn.)	Stahlscheiben-Rad 4 (1 Reserve) 4 1/2 J x 13 112 mm 5 <u>Isabella</u> 5,90 x 13 <u>Straße</u> <u>Autobahn</u> 1,5 atü 1,9 atü 1,7 atü 2,0 atü 290 mm	<u>Isabella-Combi</u> 6,40 x 13 <u>Straße</u> <u>Autobahn</u> 1,5 atü 1,9 atü *1,7-1,9 atü 2,0-2,5 atü 304 mm * je nach Belastung
--	---	--	---

Gruppe 30 Motor

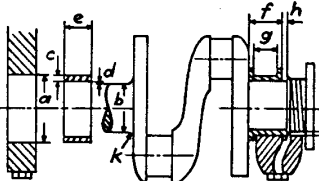
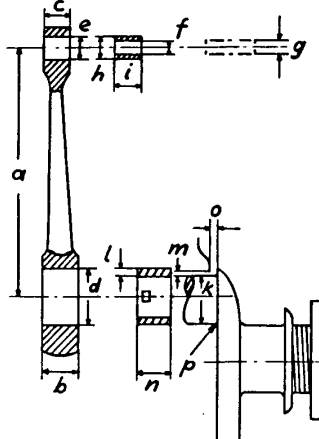
	Zylinderblock a) auf der Kopfplatte des Zylinderblocks eingeschlagen (Zyl. Bohrungskennzahl)	b) Grenzmaß der Zyl. Bohrung 75,000 \varnothing mm - 75,009 \varnothing mm 75,010 \varnothing mm - 75,019 \varnothing mm 75,020 \varnothing mm - 75,029 \varnothing mm 75,030 \varnothing mm - 75,039 \varnothing mm 75,500 \varnothing mm - 75,509 \varnothing mm 76,000 \varnothing mm - 76,009 \varnothing mm	c) Kolben \varnothing 74,96 \varnothing mm 74,97 \varnothing mm 74,98 \varnothing mm 74,99 \varnothing mm 75,46 \varnothing mm 75,96 \varnothing mm
	Reparaturstufe Übermaß 1 0,5 mm 2 1,0 mm Spaltmaß 0 mm		

<p>Kurbelwelle Härtung bis Motor 1 067 727 ab Motor 1 067 728</p> <p>Lagerung der Kurbelwelle</p> <p>a) Lagerbohrung im Gehäuse Kurbelwellenlagerschalen</p> <table border="1"> <tr><td>normal</td><td></td></tr> <tr><td>Reparaturstufe 1</td><td>Untermaß 0,25 mm</td></tr> <tr><td>2</td><td>0,5 mm</td></tr> <tr><td>3</td><td>0,75 mm</td></tr> <tr><td>4</td><td>1,0 mm</td></tr> </table> <p>d) Lagerspiel der Hauptlager e) Breite der Lagerschale II. u. III. Lager f) (Paßlager) I. Lager</p> <p>g) Innenbreite der I. Lagerschale h) Axialspiel des Paßlagers Werkstoff der Lagerschalen Anzugsmoment d. Hauptlagerschr. i) Einbauspiel am Öl-Rücklaufgew. zulässiger Schlag i. mittl. Hauptlager zulässige Unrundung im Hauptlager zulässige Konizität in Lagerlänge k) Schleifradien der Lagerzapfen</p>	normal		Reparaturstufe 1	Untermaß 0,25 mm	2	0,5 mm	3	0,75 mm	4	1,0 mm	<p>geschlagen in einem Stück Einsatz gehärtet weichnitriert Achtung! Diese Kurbelwelle darf nicht nachgeschliffen werden! Weichnitrierte Kurbelwellen mit Untermaß- Lagerzapfen sind im Austausch lieferbar!</p> <p>3 mal 59 \varnothing H 6 mm = (+ 0,19)</p> <table border="1"> <tr><th>b) für Zapfen \varnothing</th><th>c) Wandstärke</th></tr> <tr><td>55 h 6 mm \Rightarrow</td><td>1,986 - 1,980 mm</td></tr> <tr><td>54,75 h 6 mm \Rightarrow</td><td>2,111 - 2,105 mm</td></tr> <tr><td>54,5 h 5 mm \Rightarrow</td><td>-0,019 2,236 - 2,230 mm</td></tr> <tr><td>54,25 h 6 mm \Rightarrow</td><td>2,361 - 2,355 mm</td></tr> <tr><td>54 h 6 mm \Rightarrow</td><td>2,486 - 2,480 mm</td></tr> </table> <p>0,028 - 0,078 mm 28 \pm 0,1 mm</p> <table border="1"> <tr><th>normal</th><th>Reparatur- stufe</th><th>1</th><th>2</th><th>3</th><th>4</th></tr> <tr><td>38,85 mm (+0,05)</td><td>39,20</td><td>39,40</td><td>39,60</td><td>39,80</td><td></td></tr> <tr><td></td><td></td><td>35 + 0,04 mm</td><td></td><td></td><td></td></tr> <tr><td></td><td></td><td>0,10 - 0,19 mm</td><td></td><td></td><td></td></tr> <tr><td></td><td></td><td>Super - Mikro</td><td></td><td></td><td></td></tr> <tr><td></td><td></td><td>in 2 Stufen anziehen! 6 mkg \rightarrow 10 mkg</td><td></td><td></td><td></td></tr> <tr><td></td><td></td><td>0,12 - 0,19 mm</td><td></td><td></td><td></td></tr> <tr><td></td><td></td><td>0,04 mm bei Einspannen in den Endlagern</td><td></td><td></td><td></td></tr> <tr><td></td><td></td><td>0,025 mm</td><td></td><td></td><td></td></tr> <tr><td></td><td></td><td>0,01 mm</td><td></td><td></td><td></td></tr> <tr><td></td><td></td><td>2,8 \pm 0,2 mm</td><td></td><td></td><td></td></tr> </table>	b) für Zapfen \varnothing	c) Wandstärke	55 h 6 mm \Rightarrow	1,986 - 1,980 mm	54,75 h 6 mm \Rightarrow	2,111 - 2,105 mm	54,5 h 5 mm \Rightarrow	-0,019 2,236 - 2,230 mm	54,25 h 6 mm \Rightarrow	2,361 - 2,355 mm	54 h 6 mm \Rightarrow	2,486 - 2,480 mm	normal	Reparatur- stufe	1	2	3	4	38,85 mm (+0,05)	39,20	39,40	39,60	39,80				35 + 0,04 mm						0,10 - 0,19 mm						Super - Mikro						in 2 Stufen anziehen! 6 mkg \rightarrow 10 mkg						0,12 - 0,19 mm						0,04 mm bei Einspannen in den Endlagern						0,025 mm						0,01 mm						2,8 \pm 0,2 mm				
normal																																																																																										
Reparaturstufe 1	Untermaß 0,25 mm																																																																																									
2	0,5 mm																																																																																									
3	0,75 mm																																																																																									
4	1,0 mm																																																																																									
b) für Zapfen \varnothing	c) Wandstärke																																																																																									
55 h 6 mm \Rightarrow	1,986 - 1,980 mm																																																																																									
54,75 h 6 mm \Rightarrow	2,111 - 2,105 mm																																																																																									
54,5 h 5 mm \Rightarrow	-0,019 2,236 - 2,230 mm																																																																																									
54,25 h 6 mm \Rightarrow	2,361 - 2,355 mm																																																																																									
54 h 6 mm \Rightarrow	2,486 - 2,480 mm																																																																																									
normal	Reparatur- stufe	1	2	3	4																																																																																					
38,85 mm (+0,05)	39,20	39,40	39,60	39,80																																																																																						
		35 + 0,04 mm																																																																																								
		0,10 - 0,19 mm																																																																																								
		Super - Mikro																																																																																								
		in 2 Stufen anziehen! 6 mkg \rightarrow 10 mkg																																																																																								
		0,12 - 0,19 mm																																																																																								
		0,04 mm bei Einspannen in den Endlagern																																																																																								
		0,025 mm																																																																																								
		0,01 mm																																																																																								
		2,8 \pm 0,2 mm																																																																																								
<p>Pleuelstange</p> <p>a) Länge b) Breite unten c) Breite oben d) Bohrungs \varnothing unten e) Bohrungs \varnothing oben</p> <p>Pleuelbüchse</p> <p> Bolzen Kennzeichen Farbe (weiß) (schwarz)</p> <p>h) Außen \varnothing i) Breite</p> <p>Pleuellagerschalen</p> <table border="1"> <tr><td>normal</td><td></td></tr> <tr><td>Reparaturstufe 1</td><td>Untermaß 0,25 mm</td></tr> <tr><td>2</td><td>0,5 mm</td></tr> <tr><td>3</td><td>0,75 mm</td></tr> <tr><td>4</td><td>1,0 mm</td></tr> </table> <p>m) Lagerspiel der Pleuellager n) Breite der Pleuellagerschalen o) Axialspiel der Pleuelstange Werkstoff der Lagerschalen Anzugsmoment f. Pleuelschrauben zul. Gewichtsunterschied d. Pleuelst. zul. Unrundung im Pleuellagerzapfen p) Schleifradien der Lagerzapfen</p>	normal		Reparaturstufe 1	Untermaß 0,25 mm	2	0,5 mm	3	0,75 mm	4	1,0 mm	<p>160 \pm 0,15 mm 29 - 0,065 - 0,117 mm 26 + 0,3 mm 52 \varnothing H 6 mm = (+ 0,19) 25 \varnothing H 7 mm = (+ 0,25)</p> <table border="1"> <tr><th>f) Büchsen \varnothing (eingebaut)</th><th>g) Bolzen \varnothing</th></tr> <tr><td>22,012 - 22,014 mm</td><td>22,000 - 21,997 mm</td></tr> <tr><td>22,007 - 22,009 mm</td><td>21,997 - 21,994 mm</td></tr> </table> <p>25 \varnothing s 6 mm (+ 0,048) (+ 0,035)</p> <p>26 \pm 0,15 mm</p> <table border="1"> <tr><th>k) Zapfen \varnothing</th><th>l) Wandstärke</th></tr> <tr><td>48 j 6 mm \Rightarrow</td><td>1,988 - 1,978 mm</td></tr> <tr><td>47,75 j 6 mm \Rightarrow</td><td>2,113 - 2,103 mm</td></tr> <tr><td>47,5 j 6 mm \Rightarrow</td><td>+ 0,011 2,238 - 2,228 mm</td></tr> <tr><td>47,25 j 6 mm \Rightarrow</td><td>- 0,005 2,363 - 2,353 mm</td></tr> <tr><td>47 j 6 mm \Rightarrow</td><td>2,488 - 2,478 mm</td></tr> </table> <p>0,013 - 0,068 mm 25 \pm 0,1 mm 0,065 - 0,150 mm Dreistofflager 4,5 mkg höchstens 5 g 0,006 mm 2,8 \pm 0,2 mm</p>	f) Büchsen \varnothing (eingebaut)	g) Bolzen \varnothing	22,012 - 22,014 mm	22,000 - 21,997 mm	22,007 - 22,009 mm	21,997 - 21,994 mm	k) Zapfen \varnothing	l) Wandstärke	48 j 6 mm \Rightarrow	1,988 - 1,978 mm	47,75 j 6 mm \Rightarrow	2,113 - 2,103 mm	47,5 j 6 mm \Rightarrow	+ 0,011 2,238 - 2,228 mm	47,25 j 6 mm \Rightarrow	- 0,005 2,363 - 2,353 mm	47 j 6 mm \Rightarrow	2,488 - 2,478 mm																																																													
normal																																																																																										
Reparaturstufe 1	Untermaß 0,25 mm																																																																																									
2	0,5 mm																																																																																									
3	0,75 mm																																																																																									
4	1,0 mm																																																																																									
f) Büchsen \varnothing (eingebaut)	g) Bolzen \varnothing																																																																																									
22,012 - 22,014 mm	22,000 - 21,997 mm																																																																																									
22,007 - 22,009 mm	21,997 - 21,994 mm																																																																																									
k) Zapfen \varnothing	l) Wandstärke																																																																																									
48 j 6 mm \Rightarrow	1,988 - 1,978 mm																																																																																									
47,75 j 6 mm \Rightarrow	2,113 - 2,103 mm																																																																																									
47,5 j 6 mm \Rightarrow	+ 0,011 2,238 - 2,228 mm																																																																																									
47,25 j 6 mm \Rightarrow	- 0,005 2,363 - 2,353 mm																																																																																									
47 j 6 mm \Rightarrow	2,488 - 2,478 mm																																																																																									

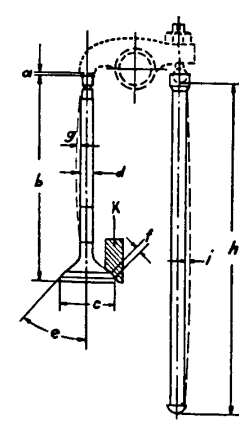
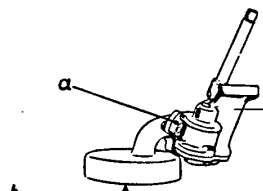
	<p><u>Kolben mit Kolbenbolzen</u> <u>Kolben-Typ</u></p> <p>a) Kompressionsring in Nute I b) Winkelring II c) Nasenring III d) Ölschlitzring IV e) Höhengspiel der Kolbenringe f. Ringe f) Spaltmaß an der Stoßstelle f. Ringe g) Kolbenbolzen \varnothing Kennzeichen Farbe weiß schwarz h) Innen \varnothing i) Länge k) Kolbenbolzensicherung</p>	<p>Kolben \varnothing (siehe unter Zyl.-Block) Mahle 2 K 14 195/12 NÜral 7553 10 f 75 / 68,4 x 2 12 f 75 / 68,4 x 2 30 f 75 / 68,4 x 2,5 41 f 75 / 68,4 x 4,5 I-III 0,035-0,062 mm IV 0,025-0,052 mm I-III 0,3 - 0,45 mm IV 0,25 - 0,40 mm</p> <table border="1"> <thead> <tr> <th>Kolbenbolzen</th> <th>Kolbenauge</th> </tr> </thead> <tbody> <tr> <td>22,000 - 21,997 \varnothing mm</td> <td>21,998 - 21,995 \varnothing mm</td> </tr> <tr> <td>21,997 - 21,994 \varnothing mm</td> <td>21,995 - 21,992 \varnothing mm</td> </tr> <tr> <td colspan="2">15 mm \varnothing</td> </tr> <tr> <td colspan="2">62 mm \varnothing</td> </tr> </tbody> </table> <p>Sprenging A 22 DIN 73123</p>	Kolbenbolzen	Kolbenauge	22,000 - 21,997 \varnothing mm	21,998 - 21,995 \varnothing mm	21,997 - 21,994 \varnothing mm	21,995 - 21,992 \varnothing mm	15 mm \varnothing		62 mm \varnothing																							
Kolbenbolzen	Kolbenauge																																	
22,000 - 21,997 \varnothing mm	21,998 - 21,995 \varnothing mm																																	
21,997 - 21,994 \varnothing mm	21,995 - 21,992 \varnothing mm																																	
15 mm \varnothing																																		
62 mm \varnothing																																		
	<p><u>Nockenwelle</u></p> <p>a) Antrieb Nockenwelle gelagert b) Bohrungs \varnothing im Gehäuse c) Nockenwellenlager Innen \varnothing (eingepreßt und nachgearbeitet) d) Breite e) Lagerzapfen \varnothing f) Lagerspiel Steuerzeiten g) Einlaß öffnet h) Einlaß schließt i) Auslaß öffnet k) Auslaß schließt l) Stößelkappen \varnothing m) Bodenhöhe n) Schwungrad \varnothing bei Zeigerspitze Schwungradverstellung</p> <p>Anzugsmoment d. Schwungradschr.</p>	<p>schrägverzahnte Stirnräder im Motorgehäuse 3 mal 45 \varnothing H 7 mm = (+ 0,025) 41 \varnothing H 7 mm = (+ 0,025) 28 \pm 0,1 mm 41 \varnothing f 7 mm = (- 0,025) (- 0,050) 0,025 - 0,075 mm bei Ventilspiel 0,38 mm gemessen!</p> <table border="1"> <thead> <tr> <th></th> <th>bei n</th> </tr> </thead> <tbody> <tr> <td>18° v. OT =</td> <td>40 mm v. OT</td> </tr> <tr> <td>56° n. UT =</td> <td>124 mm n. UT</td> </tr> <tr> <td>56° v. UT =</td> <td>124 mm v. UT</td> </tr> <tr> <td>18° n. OT =</td> <td>40 mm n. OT</td> </tr> </tbody> </table> <p>22 \varnothing f 7 mm (- 0,020) (- 0,041) 5,5 mm 255 \varnothing mm an OT-Punkt-Markierung 1° auf dem Schwungrad \varnothing gemessen bei n) = 2,22 mm 6 mkg</p>		bei n	18° v. OT =	40 mm v. OT	56° n. UT =	124 mm n. UT	56° v. UT =	124 mm v. UT	18° n. OT =	40 mm n. OT																						
	bei n																																	
18° v. OT =	40 mm v. OT																																	
56° n. UT =	124 mm n. UT																																	
56° v. UT =	124 mm v. UT																																	
18° n. OT =	40 mm n. OT																																	
	<p><u>Zylinderkopf</u> Anzugsmoment d. Zylinderkopfmuttern Reihenfolge des Anziehens</p>	<p>einteilig Spez.-Leichtmetall-Guß in 2 Stufen anziehen 6 mkg \rightarrow 10 mkg siehe Abbildung</p>																																
	<p><u>Ventilfeder</u></p> <p>a) ungespannte Länge b) geschlossenes Ventil c) geöffnetes Ventil d) oberer Innen \varnothing e) unterer Innen \varnothing f) Drahtstärke wirksame Windungen Gesamtwindungen</p>	<table border="1"> <thead> <tr> <th colspan="2">innere Feder</th> <th colspan="2">äußere Feder</th> </tr> </thead> <tbody> <tr> <td>45 mm Federbel. 0 kg</td> <td>36,7 mm " 8,6 kg</td> <td>48,5 mm Federbel. 0 kg</td> <td>40,5 mm " 17,5 kg</td> </tr> <tr> <td>26,7 mm " 18,5 kg</td> <td></td> <td>30,5 mm " 44,0 kg</td> <td></td> </tr> <tr> <td colspan="2">} 16,8 \varnothing</td> <td colspan="2">23,5 \varnothing mm</td> </tr> <tr> <td colspan="2"></td> <td colspan="2">25,3 \varnothing mm</td> </tr> <tr> <td colspan="2">2,6 mm</td> <td colspan="2">4 mm</td> </tr> <tr> <td colspan="2">6 2/3</td> <td colspan="2">4 3/4</td> </tr> <tr> <td colspan="2">9</td> <td colspan="2">7</td> </tr> </tbody> </table>	innere Feder		äußere Feder		45 mm Federbel. 0 kg	36,7 mm " 8,6 kg	48,5 mm Federbel. 0 kg	40,5 mm " 17,5 kg	26,7 mm " 18,5 kg		30,5 mm " 44,0 kg		} 16,8 \varnothing		23,5 \varnothing mm				25,3 \varnothing mm		2,6 mm		4 mm		6 2/3		4 3/4		9		7	
innere Feder		äußere Feder																																
45 mm Federbel. 0 kg	36,7 mm " 8,6 kg	48,5 mm Federbel. 0 kg	40,5 mm " 17,5 kg																															
26,7 mm " 18,5 kg		30,5 mm " 44,0 kg																																
} 16,8 \varnothing		23,5 \varnothing mm																																
		25,3 \varnothing mm																																
2,6 mm		4 mm																																
6 2/3		4 3/4																																
9		7																																
	<p><u>Ventilführung</u></p> <p>a) Länge b) Außen \varnothing c) Innen \varnothing Material</p>	<p>60 mm 15 \varnothing s 6 = (+ 0,028) (- 0,039) 9 \varnothing H 8 = (+ 0,022) Sondergußeisen</p>																																

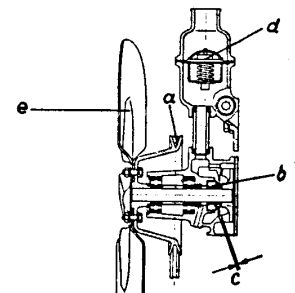
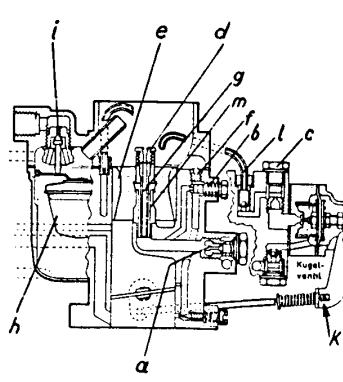
<p>a) Ventilspiel bei warmem Motor</p> <p>b) Ventil - Länge</p> <p>c) Regel \varnothing</p> <p>d) Schaftstärke</p> <p>e) Kegelwinkel</p> <p>f) Sitzbreite im Sitzring</p> <p>g) zulässiger Schlag am Ventilschaft zulässiger Schlag am Ventilkegel</p> <p>h) Stoßstangen-Länge</p> <p>i) zulässiger Schlag der Stoßstange</p> <p>k) Ventilsitzring</p>	<p>Einlaß und Auslaß 0,2 mm</p> <table border="0"> <tr> <td><u>Einlaß</u></td> <td><u>Auslaß</u></td> </tr> <tr> <td>110 mm</td> <td>111 mm</td> </tr> <tr> <td>35 \varnothing mm</td> <td>30 \varnothing mm</td> </tr> <tr> <td colspan="2">9 mm \varnothing e 7 = (-0,025) (-0,040)</td> </tr> <tr> <td colspan="2">45° 30'</td> </tr> <tr> <td>1,2 - 1,4 mm</td> <td>2,0 - 2,2 mm</td> </tr> <tr> <td colspan="2">0,02 mm</td> </tr> <tr> <td colspan="2">0,02 mm</td> </tr> <tr> <td colspan="2">267,8 - 0,8 mm</td> </tr> <tr> <td colspan="2">0,1 - 0,2 mm</td> </tr> </table> <p>Bleistahl oder Chrom-Nickelstahl</p>	<u>Einlaß</u>	<u>Auslaß</u>	110 mm	111 mm	35 \varnothing mm	30 \varnothing mm	9 mm \varnothing e 7 = (-0,025) (-0,040)		45° 30'		1,2 - 1,4 mm	2,0 - 2,2 mm	0,02 mm		0,02 mm		267,8 - 0,8 mm		0,1 - 0,2 mm																											
<u>Einlaß</u>	<u>Auslaß</u>																																														
110 mm	111 mm																																														
35 \varnothing mm	30 \varnothing mm																																														
9 mm \varnothing e 7 = (-0,025) (-0,040)																																															
45° 30'																																															
1,2 - 1,4 mm	2,0 - 2,2 mm																																														
0,02 mm																																															
0,02 mm																																															
267,8 - 0,8 mm																																															
0,1 - 0,2 mm																																															
<p>a) <u>Ölpumpe</u> Bauart Antrieb</p> <p>b) Ansaug-Grobfilterung Öldruck bei mittlerer Drehzahl Kurbelgehäuse-Entlüftung</p>	<p>Zahnradpumpe von der Nockenwelle</p> <p>Drahtsieb vor der Ölpumpe mindestens 1,5 atü (bei warmem Motor)</p> <p>1 Öldunstentlüfter ins Freie</p>																																														
<p>a) <u>Nebenstromölfiltergehäuse</u> Anzugsmoment</p> <p>b) Filtereinsatz wahlweise</p>	<p>Borgward</p> <p>2,5 mkg</p> <p>Knecht EN 108 Bosch FJSJ 24 S 3 Z Hengst E 11.14 From C 842</p>																																														
<p><u>Wasserpumpe</u></p> <p>a) Antrieb der Wasserpumpe</p> <p>b) Abdichtung der Wasserpumpe</p> <p>c) Spaltmaß zw. Gehäuse u. Flügelrad Schmierung</p> <p>d) Thermostat Öffnungstemperatur</p> <p>e) Ventilator \varnothing</p>	<p>Flügelpumpe mit Ventilator zusammen am Motorgehäuse befestigt von der Kurbelwelle durch Keilriemen 9,5 x 925/975</p> <p>Gleitringdichtung AB 16,5.35.16/6 0,3 - 0,5 mm</p> <p>Schmierfettbüchse 80° ± 2° C</p> <p>355 \varnothing mm (Spezial 380 \varnothing mm)</p> <p>dyn. ausgewuchtet</p>																																														
<p><u>Vergaser</u></p> <p>a) Hauptdüse</p> <p>b) Leerlaufdüse</p> <p>c) Pumpendüse</p> <p>d) Luftkorrekturdüse</p> <p>e) Lufttrichter</p> <p>f) Leerlaufdüse Starterkraftstoffdüse Starterluftdüse</p> <p>g) Mischrohr</p> <p>h) Schwimmergewicht</p> <p>i) Schwimrnadelventil Einspritzpumpe</p> <p>k) Splintstellung</p> <p>l) Einspritzrohr</p> <p>m) Mischrohrträger</p>	<p>Solex 32 PJCB</p> <table border="0"> <tr> <td></td> <td>130</td> <td>110</td> </tr> <tr> <td></td> <td>55</td> <td>57</td> </tr> <tr> <td></td> <td>40</td> <td></td> </tr> <tr> <td></td> <td>175</td> <td>180</td> </tr> <tr> <td></td> <td>26</td> <td>23</td> </tr> <tr> <td></td> <td>1,6</td> <td></td> </tr> <tr> <td></td> <td>150</td> <td></td> </tr> <tr> <td></td> <td>4</td> <td></td> </tr> <tr> <td></td> <td>35</td> <td></td> </tr> <tr> <td></td> <td>5,7 g</td> <td></td> </tr> <tr> <td></td> <td>1,5 \varnothing mm</td> <td></td> </tr> <tr> <td></td> <td colspan="2">Nr. 73 reich 0,9 - 1,2 cm³/Hub</td> </tr> <tr> <td></td> <td colspan="2">mitte</td> </tr> <tr> <td></td> <td colspan="2">niedrig (0,8)</td> </tr> <tr> <td></td> <td colspan="2">Res. 5,5</td> </tr> </table>		130	110		55	57		40			175	180		26	23		1,6			150			4			35			5,7 g			1,5 \varnothing mm			Nr. 73 reich 0,9 - 1,2 cm ³ /Hub			mitte			niedrig (0,8)			Res. 5,5		
	130	110																																													
	55	57																																													
	40																																														
	175	180																																													
	26	23																																													
	1,6																																														
	150																																														
	4																																														
	35																																														
	5,7 g																																														
	1,5 \varnothing mm																																														
	Nr. 73 reich 0,9 - 1,2 cm ³ /Hub																																														
	mitte																																														
	niedrig (0,8)																																														
	Res. 5,5																																														
<p><u>Kraftstoff-Förderpumpe</u> Antrieb</p>	<p>PE 10209 e (Solex) durch Exzenter der Nockenwelle</p>																																														

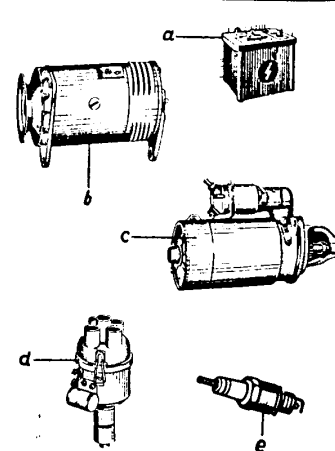
	Ansaugeräuschkämpfer mit Naßluftfilter	Knecht GD807/1 Mann & Hummel A 545-02 (- oder Spezial-Ausf. Ölbadluftfilter)
	<p>a) Batterie: Spannung u. Kapazität</p> <p>b) Lichtmaschine Regler an der Spritzwand</p> <p>c) Anlasser Übersetzung Anlasser/Schwungrad Zündspule</p> <p>d) Zündverteiler Zünderstellung (statisch) Abstand d. Unterbrecherkontakte Zündfolge Verstellwinkel des Zündverteilers - bei Motor-Drehzahl 800 U/min 1000 U/min 2000 U/min 2500 - 3200 U/min</p> <p>e) Zündkerzen (wahlweise)</p>	<p>6 Volt 84 Ah</p> <p>Bosch LJ/GEG 180/6 2300 R 22 m R RS/TBA 180/6/1</p> <p>Bosch EGD 0,6/6 A R 2 9 : 117 = (1 : 13)</p> <p>Bosch TK 6 A 3 VJR 4 BR 15</p> <p><u>im OT</u> 0,4 mm 1 - 3 - 4 - 2</p> <p><u>an Schwungrad gemessen!</u></p> <p>10° - 16° 14° - 19° 27° - 32° 32° - 37°</p> <p>Bosch W 175 T 1, Beru 175/14, Champion L-85</p>

Gruppe 31 Kupplung

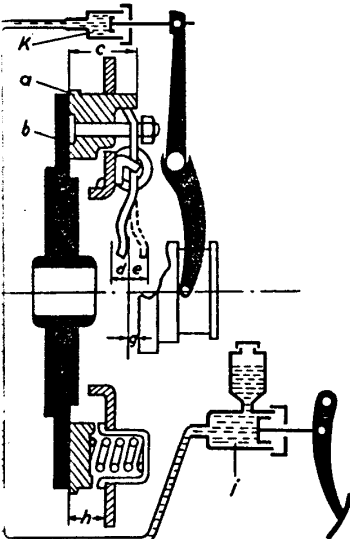
	<p>Fabrikat Typ</p> <p>a) Druckplatte</p> <p>b) Kupplungsscheibe (m. Torsionsd.)</p> <p>c) Einstellmaß von Ausrückhebel bis z. Auflagefläche d. Kuppl.-Scheibe</p> <p>d) Ausrückweg</p> <p>e) Abnutzung zulässig bis:</p> <p>f) Kupplungsscheiben-Breite Belag verbraucht bei</p> <p>g) Spiel zw. Ausrücklager und Ausrückhebel</p> <p>h) Tiefenmaß von Auflagefläche der Kupplungsanschraubplatte zur Auflagefläche der Kupplungsscheibe im Schwungrad</p> <p>i) Geberzylinder</p> <p>k) Nehmerzylinder</p>	<p>Fichtel u. Sachs</p> <p>K 12 K/SSZ Einscheiben - trocken</p> <p>K 12 K K 12 SSZ</p> <p>49 mm 8 mm 11 mm</p> <p>9,1 + 0,3 mm gespannt 9,8 + 0,3 mm ungesp. 6,6 mm gespannt 7,3 mm ungesp.</p> <p>2 mm (entspr. Fußhebelweg von ca. 20 mm)</p> <p>29 mm</p> <p>19,05 Ø mm 30 mm Hub 25,4 Ø mm 23 mm Hub</p>
--	--	--

Gruppe 32 Getriebe

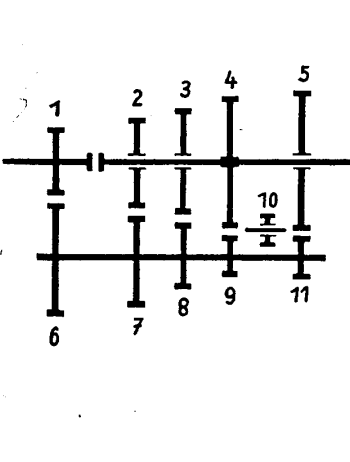
	<p>Wechselgetriebe</p> <p>1. Gang</p> <p>2. Gang</p> <p>3. Gang</p> <p>4. Gang</p> <p>Rückwärts-Gang</p> <p>Tachometerantrieb Tachometer (Anzeigebereich) Wegdrehzahl</p>	<table border="1"> <thead> <tr> <th rowspan="2">Übersetzung</th> <th colspan="2">(1 - 4 Gg. synchronisiert)</th> </tr> <tr> <th>zusammengeschaltet sind</th> <th>Zahnrad Zähnezahl</th> </tr> </thead> <tbody> <tr> <td>1 : 3,86</td> <td>$\frac{15}{6111}$</td> <td>$\frac{21}{32} \frac{38}{15}$</td> </tr> <tr> <td>1 : 2,15</td> <td>$\frac{13}{618}$</td> <td>$\frac{21}{32} \frac{32}{22}$</td> </tr> <tr> <td>1 : 1,36</td> <td>$\frac{12}{67}$</td> <td>$\frac{21}{32} \frac{25}{28}$</td> </tr> <tr> <td>1 : 1</td> <td colspan="2">direkter Antrieb</td> </tr> <tr> <td>1 : 4,06</td> <td>$\frac{14}{69} < 10$</td> <td>$\frac{21}{32} \frac{32}{12} < 19$</td> </tr> </tbody> </table> <p>Schraubenrad 5 Z, Ritzel 10 Z (= 1 : 2) 0 - 160 km/h 1,02</p>	Übersetzung	(1 - 4 Gg. synchronisiert)		zusammengeschaltet sind	Zahnrad Zähnezahl	1 : 3,86	$\frac{15}{6111}$	$\frac{21}{32} \frac{38}{15}$	1 : 2,15	$\frac{13}{618}$	$\frac{21}{32} \frac{32}{22}$	1 : 1,36	$\frac{12}{67}$	$\frac{21}{32} \frac{25}{28}$	1 : 1	direkter Antrieb		1 : 4,06	$\frac{14}{69} < 10$	$\frac{21}{32} \frac{32}{12} < 19$
Übersetzung	(1 - 4 Gg. synchronisiert)																					
	zusammengeschaltet sind	Zahnrad Zähnezahl																				
1 : 3,86	$\frac{15}{6111}$	$\frac{21}{32} \frac{38}{15}$																				
1 : 2,15	$\frac{13}{618}$	$\frac{21}{32} \frac{32}{22}$																				
1 : 1,36	$\frac{12}{67}$	$\frac{21}{32} \frac{25}{28}$																				
1 : 1	direkter Antrieb																					
1 : 4,06	$\frac{14}{69} < 10$	$\frac{21}{32} \frac{32}{12} < 19$																				