



Tie-rod joint "Isabella"

V/L
233

AUTOMOBIL- UND MOTOREN-WERKE
BREMEN - GERMANY

Bremen, Germany, May 7th, 1958

To all

Authorized Borgward Dealers and Workshops

Gentlemen:

This new edition cancels our bulletin Allg. I/221 (Edition October 10th, 1957).

In our first edition of this circular, dated October 10th, 1957 we previously pointed your attention to the so called "maintenance free" tie rods. As known these tie rods are fitted for some time as standard to our type "Isabella". They are recognizable by the specially supported joint heads which have no grease nipples.

For given reasons we want to point your attention once again to the maintenance situation of these installation parts. Please observe the remarks and instruct your service mechanics accordingly.

To prevent untimely corrosion phenomenon and wear and tear in the ball-joints they must be protected against the ingress of water, dirt etc. in case of large joint deflection. Dirt particles which have entered into the ball joint can prevent the frictionless function due to occurring movement during the operation of the vehicle. When assembling the steering linkage the hollow space between ball joint and rubber cover plate must be packed with grease. The grease filling is already made during works assembly and should meet requirements for a longer period. To warrant, however, later on sufficient protection against soiling of joints, the grease filling must be controlled from time to time and replenished, if necessary. The maintenance work must be, therefore, taken care of within the scheduled inspection services I, II and III.

If steering linkages are removed during repairs a new grease packing should be also made. A suitably prepared grease gun is especially adapted for packing and replenishing. The grease can be forced in between rubber cap and ball joint with the aid of an attached flat nozzle piece. (See drawing.)

The grease qualities to be used must comply with certain conditions, the manufacturers of the joints recommend the following brands:

Manufacturer:

Trade Mark:

BP
BV

Energrease RBB 2
FW 051
HL 14

Caltex

Marfak line
(for instance 2 HD)

Calypsol
Shell

WIA
Nerita Grease 3
Albida Grease 3

Esso

Alert M-350
Andok M-275

Mobil Oil

Mobil Grease MP
Mobil Grease BRB
No. 1

Summary:

1. Control resp. replenish grease packing of ball joint caps of "maintenance free tie rods" within maintenance services I, II and III.
2. Renew grease packing regularly when assembling.
3. Use only grease qualities specified by the manufacturer.
4. Prepare special grease gun.

Yours very truly,

CARL F. W. BORGWARD G. M. B. H.

**KUNDENDIENST
(CUSTOMERS SERVICE)
DEPT.**

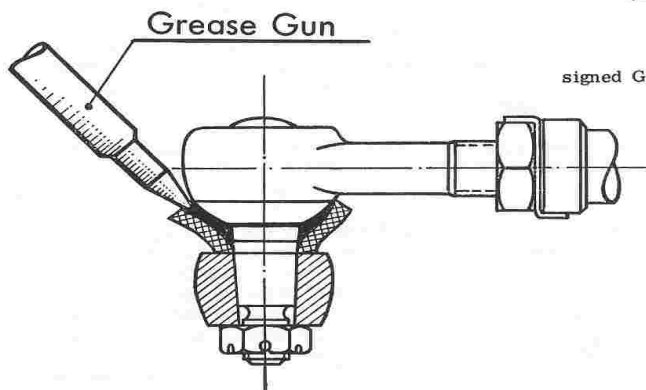

signed Grimberg

signed Wolff